

LEPA 



Lenyx

LPC801 Series

- | | |
|----------|----------------------|
| English | User's Manual |
| Deutsch | Handbuch |
| Polski | Instrukcja obsługi |
| Français | Manuel d'utilisation |
| 日本語 | ユーザ マニュアル |
| 繁中 | 使用手冊 |

Contents

Chapter 1 : Product Overview

1.1 Product View	2
1.2 Specs	5

Chapter 2 : Installation Guide

2.1 How to Remove Both Side Panels	6
2.2 How to Install the Motherboard	7
2.3 How to Install Power Supply	7
2.4 How to Install Add-on Cards	8
2.5 How to Install Optical Drive	10
2.6 How to Install Internal 3.5" Device	11
2.7 How to Install and use Hot-swap dock	12
2.8 How to Install the Radiators	13
2.9 How to Install System Fans	16
2.10 How to Clean the Dust Filter	16

Chapter 3 : Suggested Height of CPU Cooler and Length of VGA card	17
--	----

Chapter 4 : Cable Connection Description	18
---	----

1.1 Product View
Produktskizze
Rozkład elementóv
Aperçu
製品ビュー
産品外観

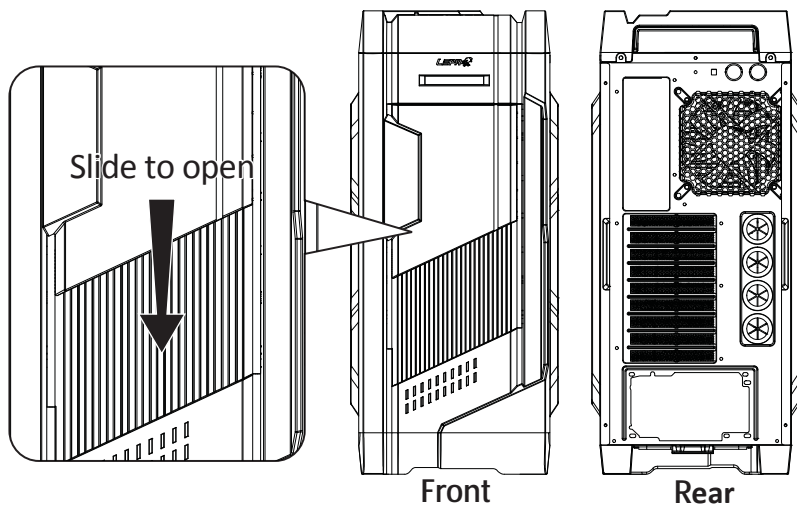

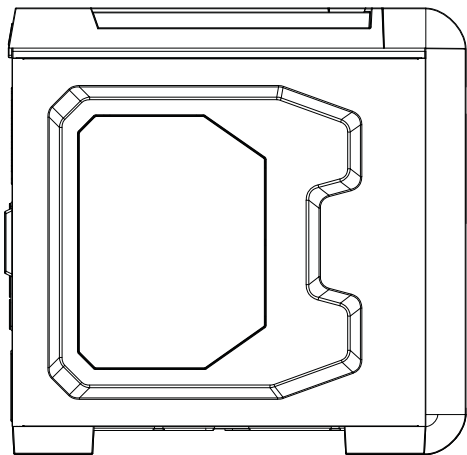

**Left side with
acrylic window**

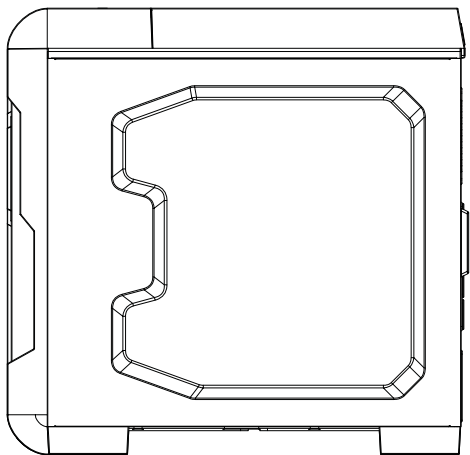

Right side

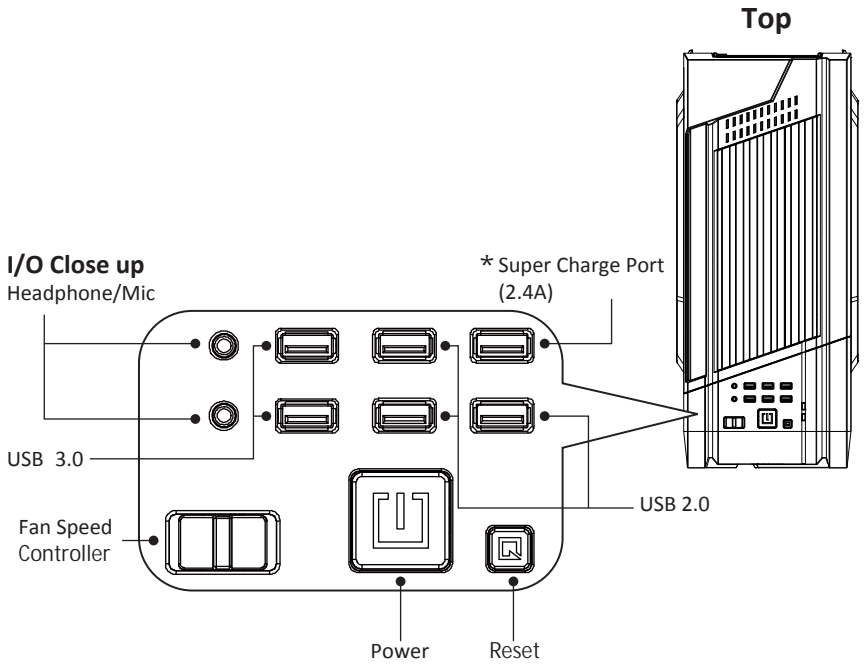

* Compliant with the USB Battery Charging (BC) specification version 1.2

1.2 Specs
Technische Daten
Dane techniczne
Spécifications
スペック
產品規格

Specs		
Model Name	LPC801A	
Dimension	D576 x W250 x H558mm	
M/B	E-ATX, ATX, Micro-ATX	
Power Supply	ATX 12V (Optional)	
I/O	2 x USB 3.0, 3 x USB 2.0, 1 x USB Super charge port (charging only), HD Audio	
Drive Bays	5.25"	3
	3.5"	6 (1 x 3.5" converted from 5.25" adapter)
	2.5"	8 (5 from 3.5" HDD tray; 2 converted from 5.25" adapter; 1 x 2.5" behind M/B tray)
Expansion Slots		9
Fan slots	Front	1 x 200mm (pre-installed) / 1 x 180mm
	Rear	1 x 140mm (pre-installed) / 1 x 120mm
	Top	1 x 200mm (pre-installed) / 1 x 180mm / 2 x 140mm / 3 x 120mm
	Bottom	2 x 120mm
Liquid cooling	Top	360 / 280 / 240 / 120mm radiator (60mm height clearance)
	Bottom	240 / 120mm radiator (60mm height clearance)
Height of CPU Cooler		194mm (7.6")
VGA Length		360mm (14.2") or 490mm (19.3") with HDD cage removed
Accessory		1 x magnetic Headset Holder 1 x 5.25" to 1 x 3.5" + 2 x 2.5" adapter
Panel Coating		Soft Grip coating

! Notice:

*Product specifications are subject to change without notice.

*Options vary by countries or regions. For further information please visit our website:
www.lepatek.com

2.1 How to Remove Both Side Panels

Entfernen der Seitenwände
Demontaż panelów bocznych
Comment retirer les deux panneaux latéraux

両サイドパネルの取り外し
兩側側板拆卸

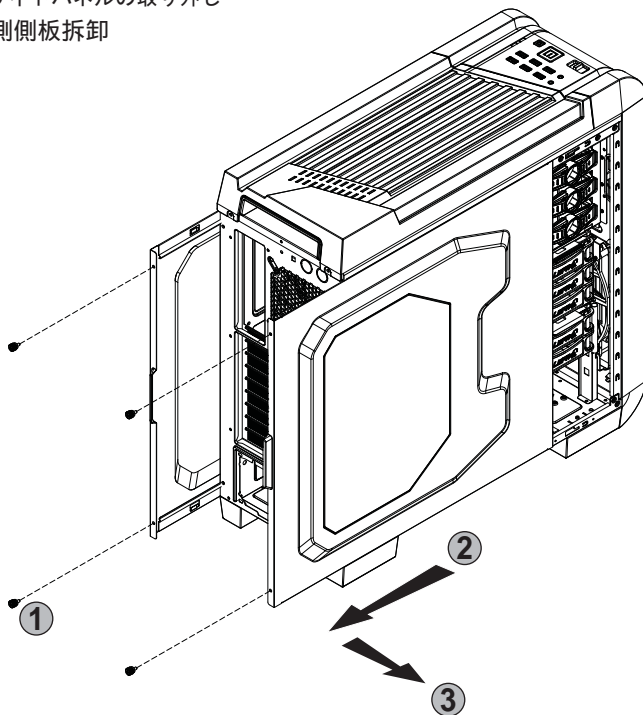

2.2 How to Install the Motherboard
So installieren Sie das Motherboard
Jak zamontować płytę główną
Comment installer la carte-mère
マザーボードの取り付け方法
安裝主機板

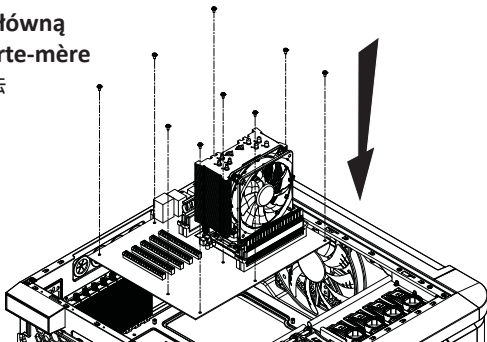

2.3 How to Install Power Supply
Netzteilinbau
Jak zainstalować zasilacz komputerowy
Comment installer l'alimentation
電源取り付け方法
安裝電源供應器

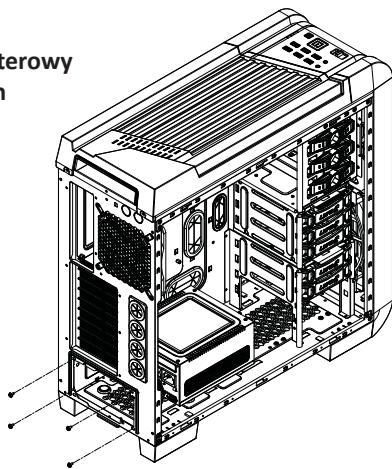

2.4 How to Install Add-on Cards
Installation von Erweiterungskarten
Instalacja kart rozszerzenia
Comment installer des cartes d'extension
アドオンカードの取り付け
安裝擴充卡

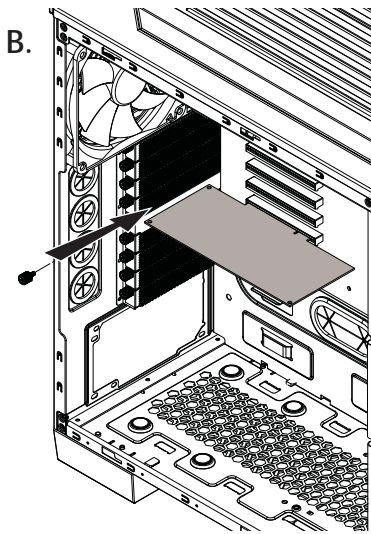
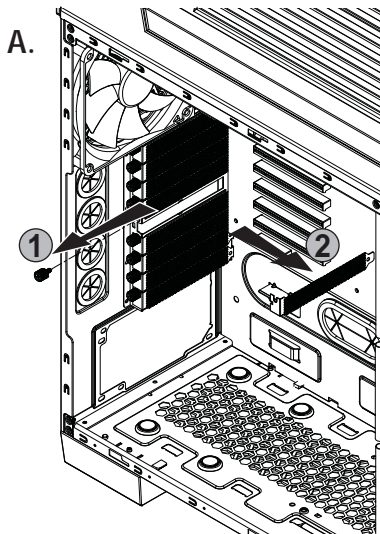

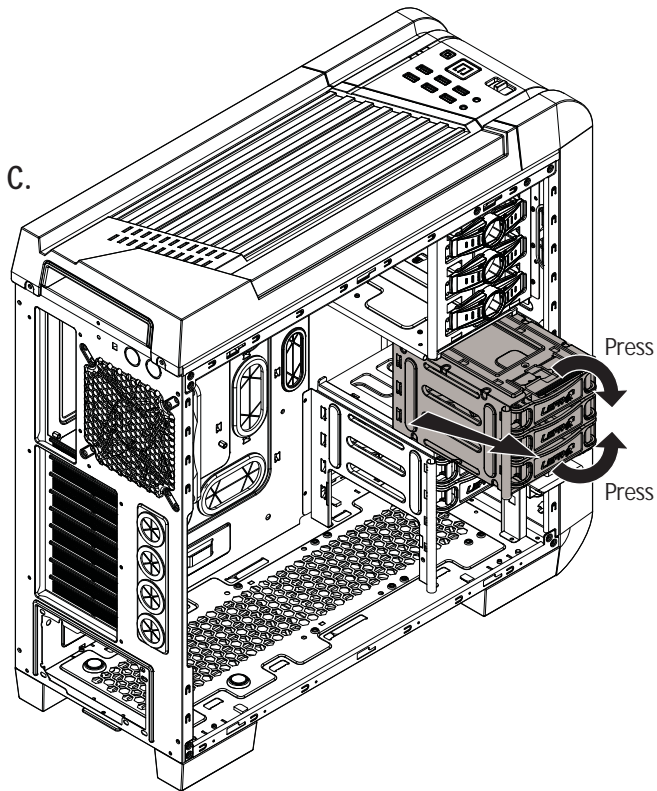

**Removable upper HDD cage to fit longer Add-on cards
(Up to 490mm)**

2.5 How to Install Optical Drive

Installation von optischen Laufwerken
Instalacja napędów optycznych
Comment installer des lecteurs optiques
光学ドライブの取り付け
光碟機安裝

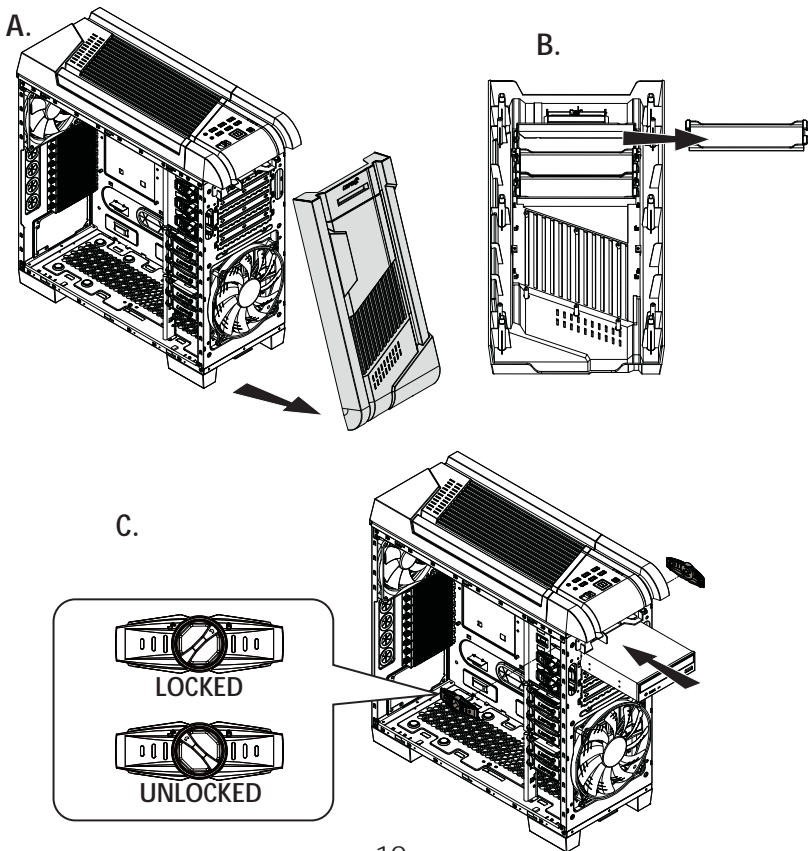

2.6 How to Install Internal 3.5" Device
 Installation von internen 3,5"-Laufwerken
 Instalacja wewnętrznych napędów 3.5"
 Comment installer un dispositif 3,5" interne
 内部3.5インチデバイスの取り付け
 安裝隱藏之3.5"裝置

*** 3.5/2.5" HDD tray**

A.

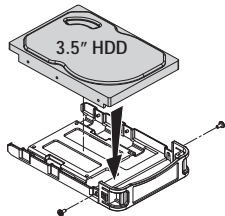

B.

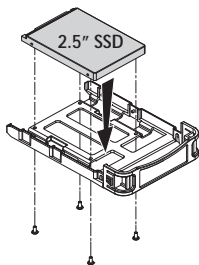

C.

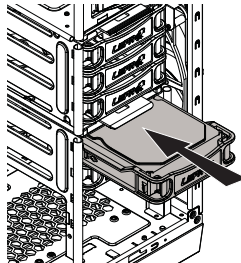

*** 2.5" SSD slot behind M/B tray**

*** 5.25" to 3.5"/2.5" adapter**

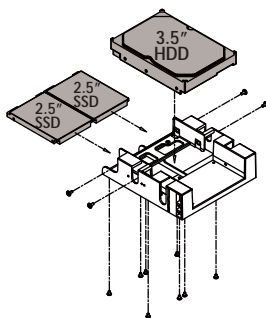
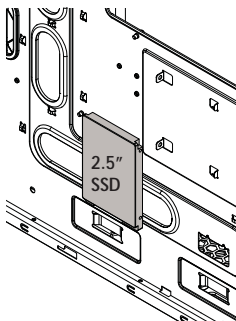

A. 5.25" to 1x 3.5" + 2x 2.5"

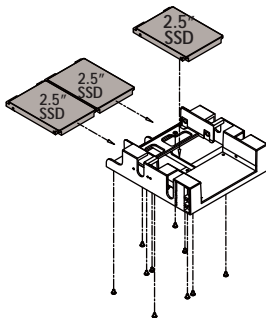

B. 5.25" to 3x 2.5"

2.7 How to Use Hot-swap Dock

Bedienung der Hot-Swap-Dockingstation auf der

Obstuga stacji dokującej z funkcją hot swap

Comment utiliser Hot-swap Dock

アドオンカードの取り付け

熱插拔硬碟使用

Installation

- 1 Connect SATA power connector to power supply
- 2 Connect SATA cable to motherboard

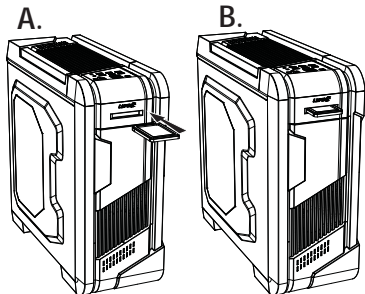

Using the 2.5" hot swap dock

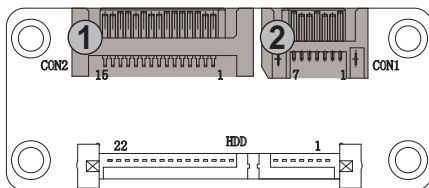

Notice:

Be sure that the SATA cable and 4-pin power cable have been connected correctly, and all the related drivers of motherboard have been installed. Then enable the "AHCI" function in the BIOS to activate the hot swap function to complete the installation.

More information please refer to the instruction of your motherboard vendor.

Stellen Sie sicher, dass das SATA-Kabel und das 4-Pin-Stromkabel korrekt angeschlossen sind und Sie alle notwendigen Mainboard-Treiber installiert haben. Schalten Sie im BIOS den AHCI-Modus ein, um die Hot-Swap-Funktion zu aktivieren. Weitere Informationen entnehmen Sie bitte dem Handbuch Ihres Mainboards.

Proszę upewnić się, czy kabel SATA oraz kabel zasilający 4P zostały podłączone prawidłowo i wszystkie sterowniki płyty głównej zostały zainstalowane poprawnie. Proszę w BIOS-ie wyłączyć tryb AHCI, aby uaktywnić funkcję hot swap. Więcej informacji można znaleźć w instrukcji obsługi płyty głównej.

Assurez-vous que le câble SATA et le câble d'alimentation à 4 broches sont bien connectés et que tous les pilotes liés à la carte mère ont été installés. Ensuite, activez la fonction "AHCI" dans le BIOS pour activer la fonction Hot Swap pour terminer l'installation. Pour plus d'informations, référez-vous à l'instruction de votre carte mère.

SATAケーブル及び4ピン電源ケーブルがしっかり接続されていることと、マザーボードに全ての関連する駆動ドライバーがインストールされたことを確認してください。そして、BIOSの中にある"AHCI"機能を有効にし、ホットスワップ機能が利用可能となります。詳細情報をご利用の場合は、マザーボードメーカーの指示をご確認ください。

請確認SATA線材及SATA電源線均已正確連接，主機板相關驅動程式均已安裝完畢，並進入BIOS啟用支援硬碟熱插拔之"AHCI"功能，以完成安裝。

2.8 How to Install the Radiators
Installation eines Radiators
Instalacja radiatora
Comment installer les radiateurs
ラジエーターの取付方法
安裝水冷散熱器

*** Installing Top Radiator**

Follow steps A~D for 240mm and A~G for 360mm Radiators.

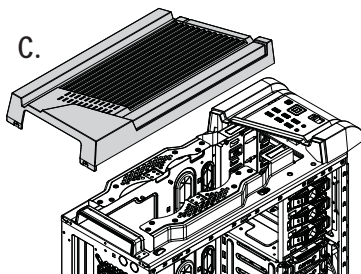
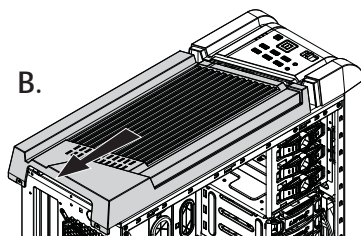
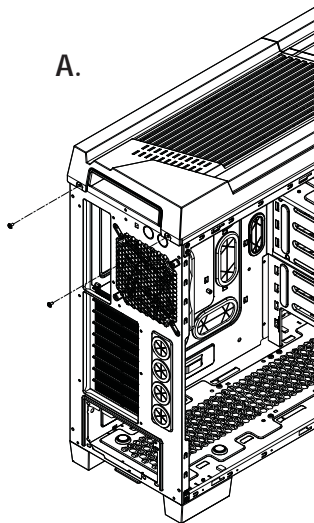

D.

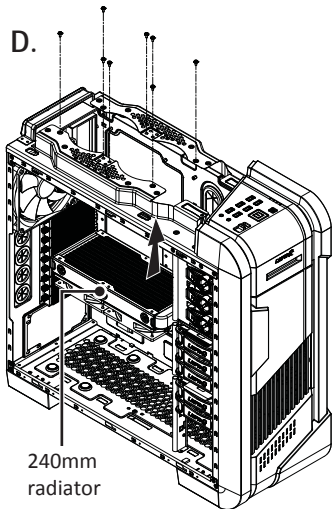

240mm
radiator

E.

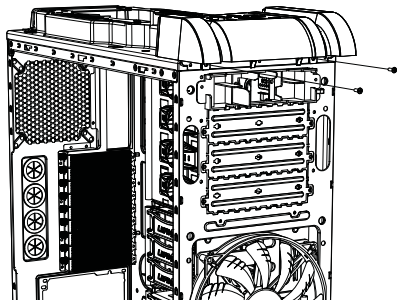

F.

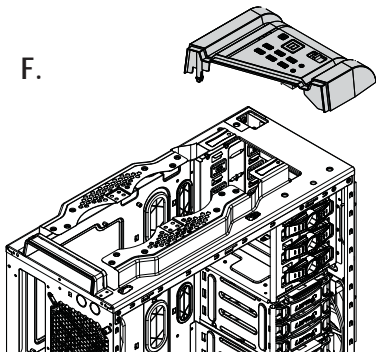

G.

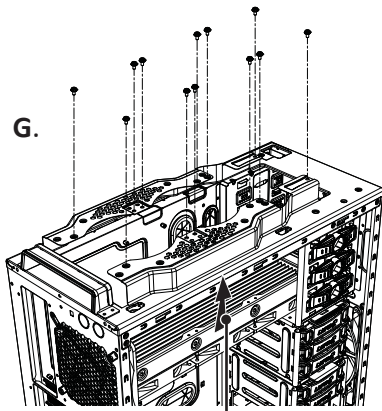

360mm
radiator

Notice : Top radiator clearance: 60mm thickness.

* Installing bottom radiator

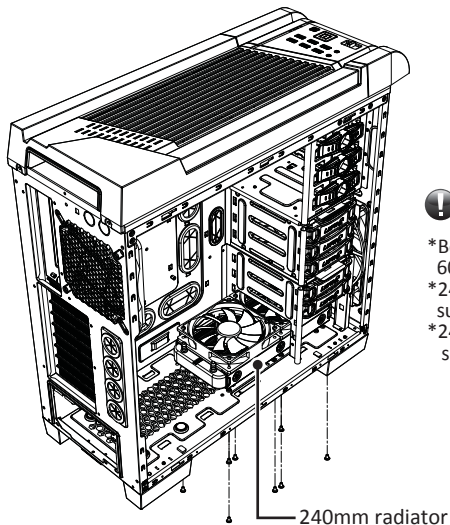

! Notice :

- *Bottom radiator clearance:
60mm thickness
- *240mm radiator at bottom PSU length
suggestion 180mm
- *240mm radiator at bottom tube length
suggestion 500mm

* Installing rear radiator

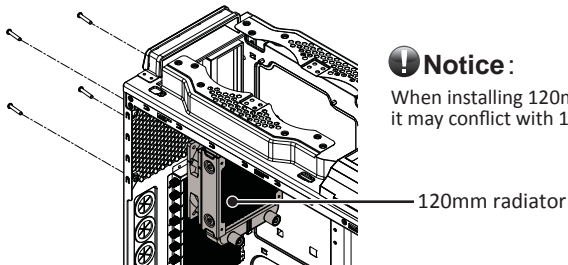

! Notice :

When installing 120mm radiator at rear,
it may conflict with 180 / 200mm fan at the side

2.9 How to Install System Fans Installation der Systemlüfter Instalacja wentylatorów systemu

Comment installer les ventilateurs du boîtier

ケースファンの取り付け

機箱風扇安裝

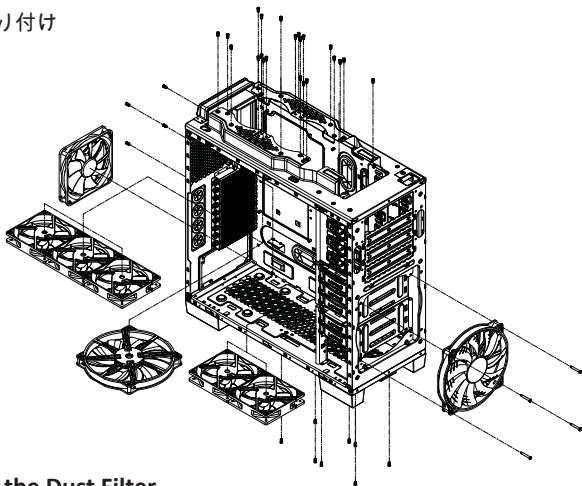

2.10 How to remove the Dust Filter

Staubfilter reinigen

Jak czyścić filtr przeciwpyłowy

Comment enlever le filtre à poussière

ダストフィルターの洗浄について

清洗冲孔網

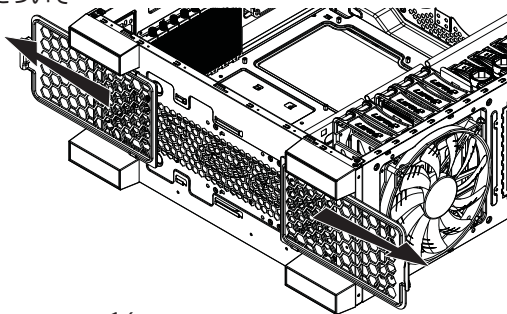

Suggested Height of CPU Cooler and Length of VGA card
Empfohlene Höhe des CPU-Kühlers und Länge der Grafikkarte
Polecana wysokość coolerów CPU oraz długość kart graficznych
Suggestion de la hauteur du CPU Cooler et longueur de la carte VGA
CPUクーラーの高さとVGAカードの長さについて
CPU 散热器高度及顯示卡長度建議

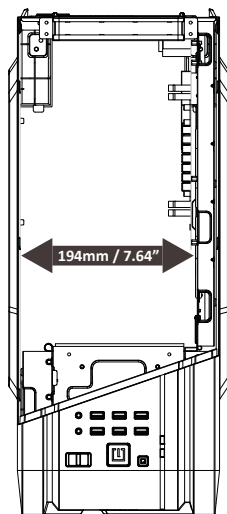
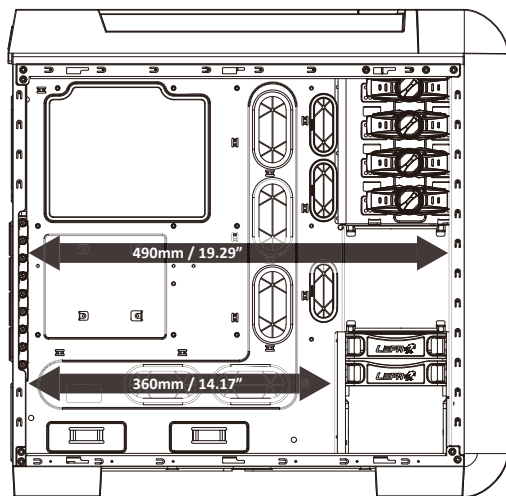

	Panel Connector	High Definition Audio (Azalia)	USB 2.0 Connector	USB 3.0 Connector	SATA Connector
Motherboard					
Cable					

! Notice:

On some motherboards, the connectors might not be exactly the same as the drawings above, please check with your motherboard manual before installing.

Bei einigen Mainboards ist der Stecker unter Umständen nicht identisch mit dem auf der Zeichnung oben.

Wyczki niektórych płyt głównych mogą odróżniać się od tych na rysunku powyżej. Proszę również przeczytać instrukcję obsługi płyty głównej przed instalacją.

Sur certaines cartes-mères, les connecteurs peuvent être différents des visuels ci-dessus, veuillez vérifier le manuel de la carte-mère avant d'installation.

マザーボードによってはコネクタ類の形状が上の図面と異なる場合がございます。詳しくはマザーボードの取扱説明書をご参照ください。

圖面所示之線材可能與使用之主機板不儘相同，安裝前請參考主機板廠所提供之說明書。



- For more information please visit our website www.lepatek.com
- Pour plus d'informations, veuillez visiter notre site Web www.lepatek.com
- Mehr Informationen finden Sie online unter www.lepatek.com
- Więcej informacji na stronie internetowej www.lepatek.com
- для получения дополнительной информации посетите наш веб-сайт www.lepatek.com
- Per maggiori informazioni visitare il nostro sito www.lepatek.com
- Para más información visite nuestra página web www.lepatek.com
- Untuk informasi lebih lanjut silahkan kunjungi website kami www.lepatek.com
- ケースの詳しい情報につきましては、弊社ウェブサイトをご覧ください www.lepatek.com
- 更多詳情請見LEPA利豹官網 www.lepatek.com

